

AIRPLANE FLIGHT MANUAL

Savannah™VG

Copyright I.C.P. 2002

Savannah™ is registered trademark solely owned by ICP Srl and their use in any form is strictly forbidden.

The content of this manual is the sole property of I.C.P. srl and cannot be reproduced by third parties in any form whatsoever without ICP's previous written authorization.

TABLE OF CONTENTS

SECTION 1	TECHNICAL DESCRIPTION
SECTION 2	LIMITATIONS
SECTION 3	EMERGENCY PROCEDURES
SECTION 4	NORMAL PROCEDURES
SECTION 5	PERFORMANCE
SECTION 6	WEIGHT AND BALANCE

TABLE OF CONTENTS

SECTION 1

TECHNICAL DESCRIPTION

Paragraph		Page
	Airplane views and dimensions	5
1.1	General specifications	7
1.2	Structure	8
1.3	Landing gear	8
1.4	Engine	8
1.5	Engine controls	8
1.6	Propeller	9
1.7	Fuel system	9
1.8	Electrical system	9
1.9	Cabin	10
1.10	Cabin features and upholstery	10
1.11	Ventilation	10
1.12	Cabin heating	10
1.13	Instrument panel	14
1.14	Flight controls	15
1.15	Flaps control system	15
1.16	Pitot-static system	15
1.17	Baggage compartment	15

AIRPLANE VIEWS (Rotax 912/912 S)

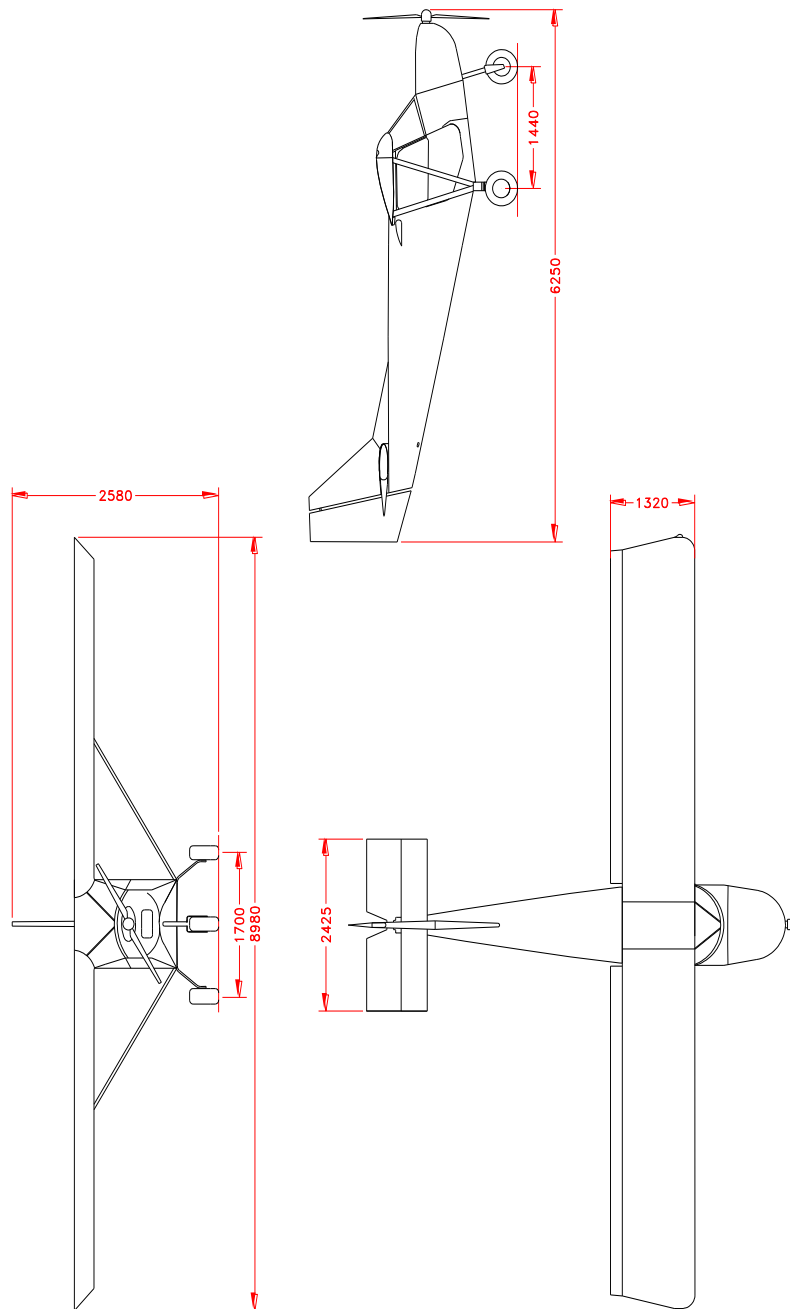

Wing span: 30ft/8.98 m
Length: 21.3ft/6.25m
Height: 8ft/2.58m
Track: 5.57ft/1.7m

AIRPLANE VIEWS (Jabiru 2200)

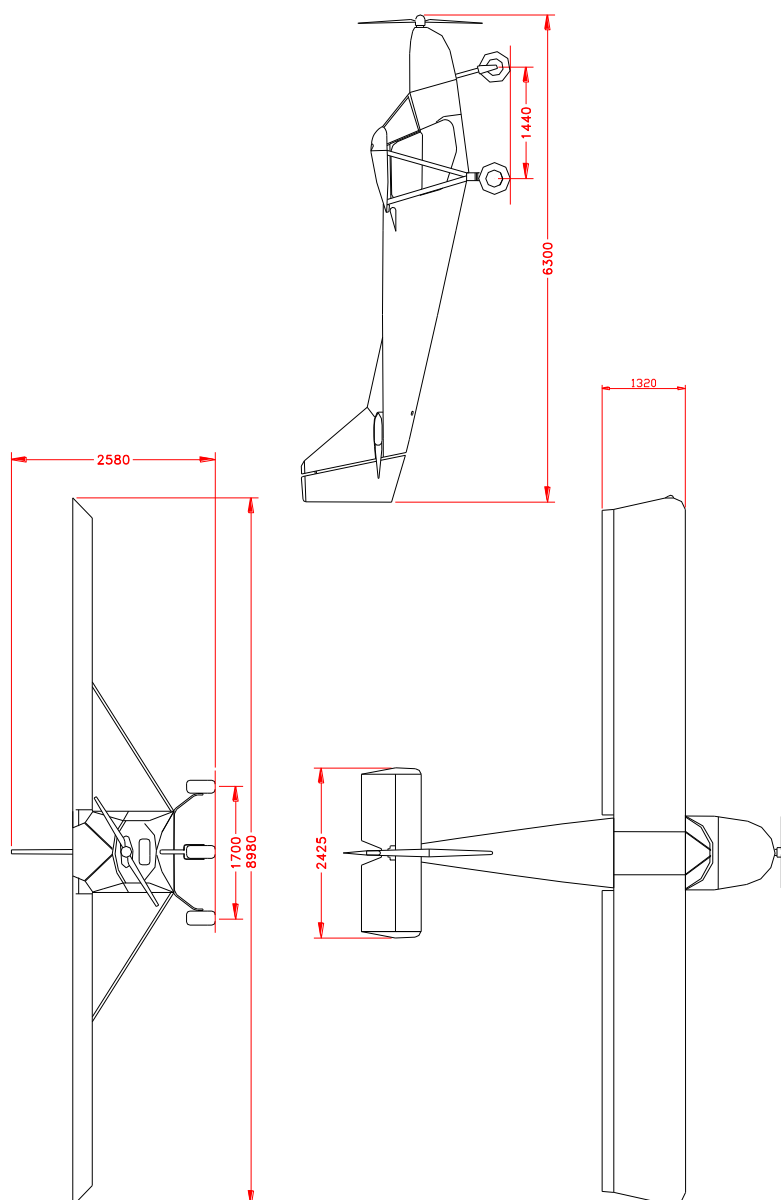

Wing span: 30ft/8.98 m
Length: 21.3ft/6.25m
Height: 8ft/2.58m
Track: 5.57ft/1.7m

1.1 GENERAL SPECIFICATIONS

Dimensions

Wing span	30.0/8.98	ft/m
Wing area	128/11.9	sq. ft/m ²
Length	21.3/6.25	ft/m
Height	8.0/2.58	ft/m
Propeller diameter	68/1.73	in/m

Weights

Maximum take-off weight *	1000/454	lbs/kg
Empty weight**	600/272	lbs/kg
Useful load	400/182	lbs/kg

*Note: If the increase maximum take-off weight kit is installed, the Max take-off weight is increased to 1234 lbs or 560Kg. Please make correction in your manual.

**NOTE: empty weight varies depending on the aiplane configuration requested by the owner. Please refer to the weight and balance document to establish your precise aircraft empty weight.

Powerplant

Engine	DIMENSION	ROTAX 912 UL	ROTAX912 ULS	JABIRU2200
Take off performance		59.6 kW (5800 rpm)	75.3 kW (5800 rpm)	(63.4 kW) 3300rpm
Displacement	cu.in/cm ³	73.9/1211	82.5/1352	134/2200
Compression ratio		9.0:1	10.5:1	8:1
Fuel consumption (75% power)	gph/lt/h	4.3/16.2	4.9/18.5	3.5/13

Fuel and oil

Fuel capacity	19/72	usgal/lt
Fuel grade	Mogas/Avgas	91/100 LL
Oil capacity	3/3.16	lt/US qts

Landing gear

Wheel track	5.6/1.7	ft/m
Tire size	6	in
Tire pressure	14.5/1	psi/bar

1.2 STRUCTURE

The aircraft is a high wing single engine, with two side-by-side seats. The wings are supported by struts and are a “high lift” NACA 650-18 modified airfoil with Junkers type flaperon (aileron + flap). The airframe structure is full-metal with load-resisting panels. The horizontal stabilizer is a simmetric bi-convex airfoil.

1.3 LANDING GEAR

<i>Issue 1/Revision 04 Feb.2018</i>	ICP Srl – S.P.16 km 15,150 14022 Castelnuovo Don Bosco (AT) Tel. 011.9927503 Fax 011.9927266
---	--

The aircraft has a tri-cycle type landing gear. The main landing gear is made by a single-piece aluminium alloy single-leaf leg. The nose landing gear has a telescopic, elastic chord shock absorber and is steerable in order to ease the taxiing.

1.4 ENGINE

This aircraft has two engine installation options: the ROTAX 912 ULS/ROTAX 912 UL or Jabiru2200. Please refer to Engine manual for any data and specifications.

WARNING: Rotax and Jabiru manufacturers issue several service and information bulletins. It is the owner's responsibility to acquire these documents available at www.rotax-aircraft-engines.com or www.jabiru.net.au.

WARNING: All engines are subject to sudden stoppage. Engine stoppage can result in crash landings, forced landings or no power landings. Such crash landings can lead to serious bodily injury or death. Never fly the aircrafts at locations, airspeeds, altitudes, or other circumstances from which a successful no power landing cannot be made.

These engines are not certificated aircraft engines. They have not received any safety or durability testing and may not conform to aircraft standards.

User assumes all risks of use and fully acknowledges by his use that he knows this engine is subject to sudden stoppage.

Note: check your country's regulations to establish the approved condition in which the airplane can be flown (VFR/IFR, Night/Day) and the type of airworthiness certificate that can be issued.

1.5 ENGINE CONTROLS

There are two push-pull throttle controls with a friction adjusting knob. In the Jabiru installation the mixture control is located near the pilot's side throttle control. In the Rotax installation the choke is in that position. The air-box control (Rotax 912 ULS) is located near the throttle control: pull for hot air to carburetors, push for cold air to carburetors (for values of temperature to maintain see chapter 2.3).

The key-operated master switch connects the electrical system to the 12V battery. The whole electrical system is protected by thermal type re-settable breakers.

The engine can be operating with the master switch OFF and the breakers OFF since the ignition system is independent. It can only be turned off by switching OFF the two magnetos switches. All of the electrical instruments and devices, including the engine starter will not operate when the master switch is OFF.

WARNING: The engine may start with the master switch OFF, if the magnetos switch (even only one) is ON and the propeller is hand rotating or windmilling. For safety, it is strongly recommended to pull-out the master switch key when exiting the cabin.

The master switch key is located near the pilot's throttle. All the switches and the engine controls are turned ON if moved UPWARD or FORWARD. Only the mixture control is operated by pulling it BACKWARD or the choke in the Rotax installation.

1.6 PROPELLER

One of the following propellers may be installed on this airplane:

- “DUC Helice”, 3 blades in carbon fiber (Rotax 912 ULS), adjustable on ground.
- “DUC Helice”, 2 blades in carbon fiber (Rotax 912 UL), adjustable on ground.
- 2 BLADES IN CARBON FIBER (Jabiru2200)

1.7 FUEL SYSTEM

With reference to fig. 1 on page 11, the fuel system is equipped with two tanks (1, 2). They are installed in the wings and have a 72 lt (19 gal) capacity. The filler caps have a vent hole. The reservoirs have an overcapacity fuel pipe ending below the wings. The left fuel tank has a visual fuel level indicator located on left wing first rib. The drain valve (5) is located in the fuel tank behind the right seat (3). A fuel reserve warning light is installed to indicate low remaining fuel in the collector tank behind the seat. The installed fuel valve (7) is held in the OPEN position by a safety wire. That safety wire can be broken in an emergency. This safety wire is used to prevent an accidental in-flight fuel valve closure leading to an engine shut-down or, even worse, to a closed fuel valve take-off. The fuel pump (8) is mechanically operated by the engine, a fuel pressure gauge is installed to check the system operation.

1.8 ELECTRICAL SYSTEM

With reference to fig.2 on page 12, the airplane’s electrical system includes a 12V battery, a generator, wiring and switches to supply and connect the engine starter, an auxiliary fuel pump, anti-collision, navigation lights and the avionics. A voltmeter is provided as a standard equipment.

The key-operated master switch connects the electrical system to the 12V battery. The whole electrical system is protected by thermal type re-settable breakers.

With the master switch OFF any electrical instrument and all other electrical devices, electric engine starter included, will not operate.

With reference to fig. 2:

- A. starter relay
- B. voltage regulator
- C. electric fuel pump
- D. master switch
- E. power supply (aux)
- F. elevator trim motor
- G. battery
- 4. RPM gauge
- 5. hourmeter
- 6. voltmeter
- 7. left head temperature
- 8. right head temperature
- 9. oil temperature
- 10. oil pressure
- 15. low voltage warning lamp
- 18. elevator trim switch
- 21-25 switches
- 26-27 breakers

FUEL SYSTEM

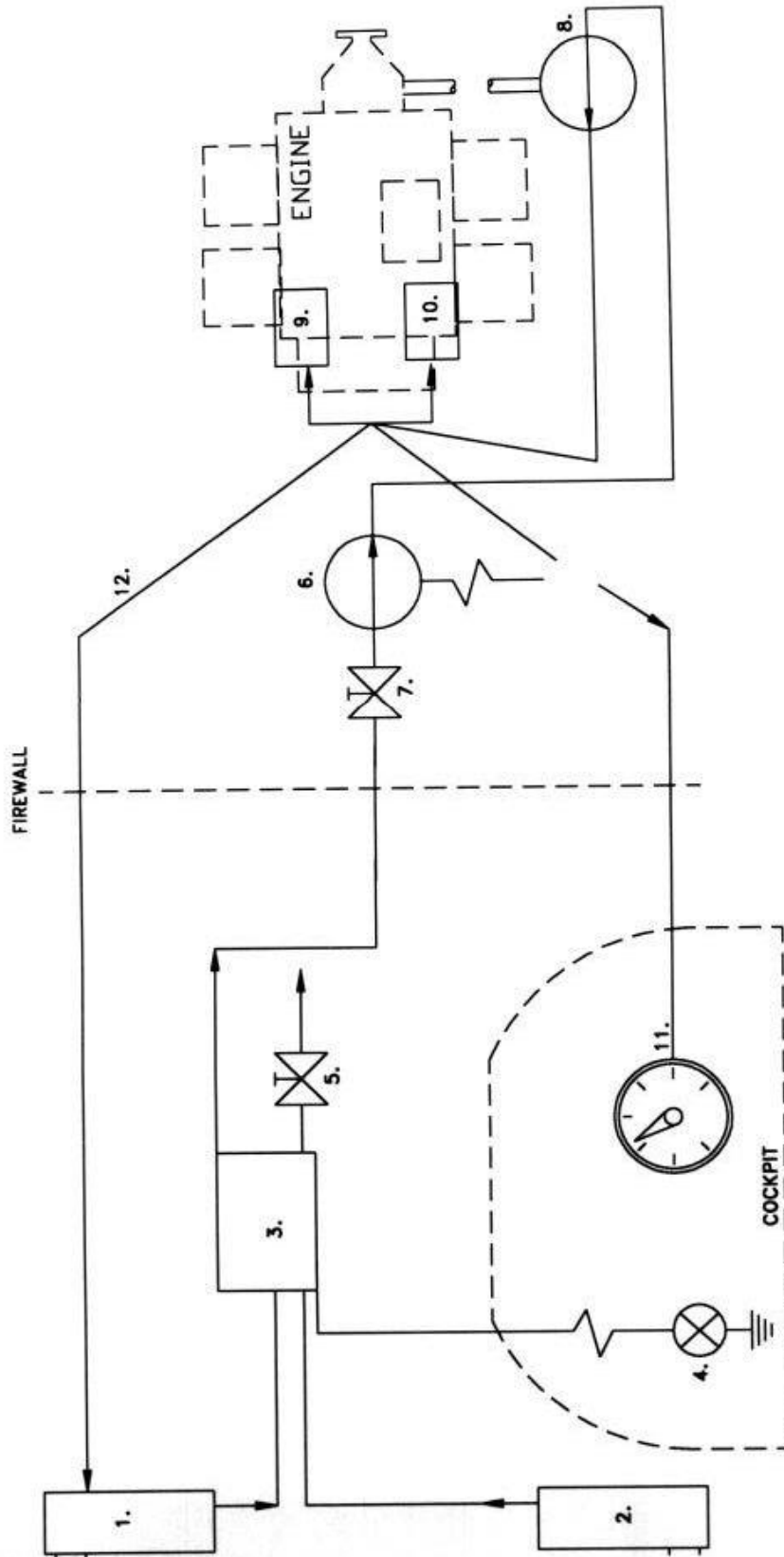

Figure nr.1

ELECTRIC SYSTEM (engines ROTAX 912 and 912S)

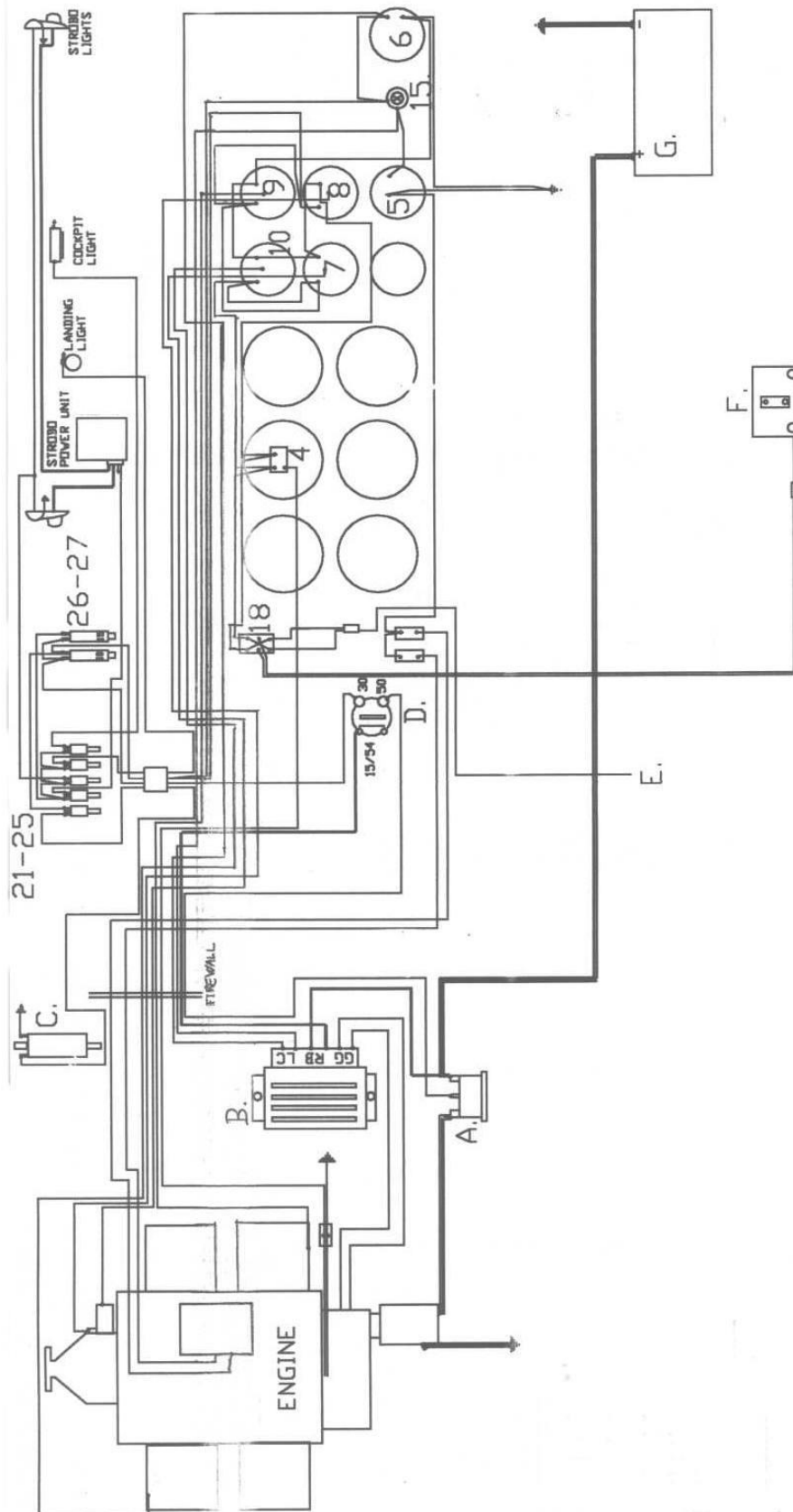
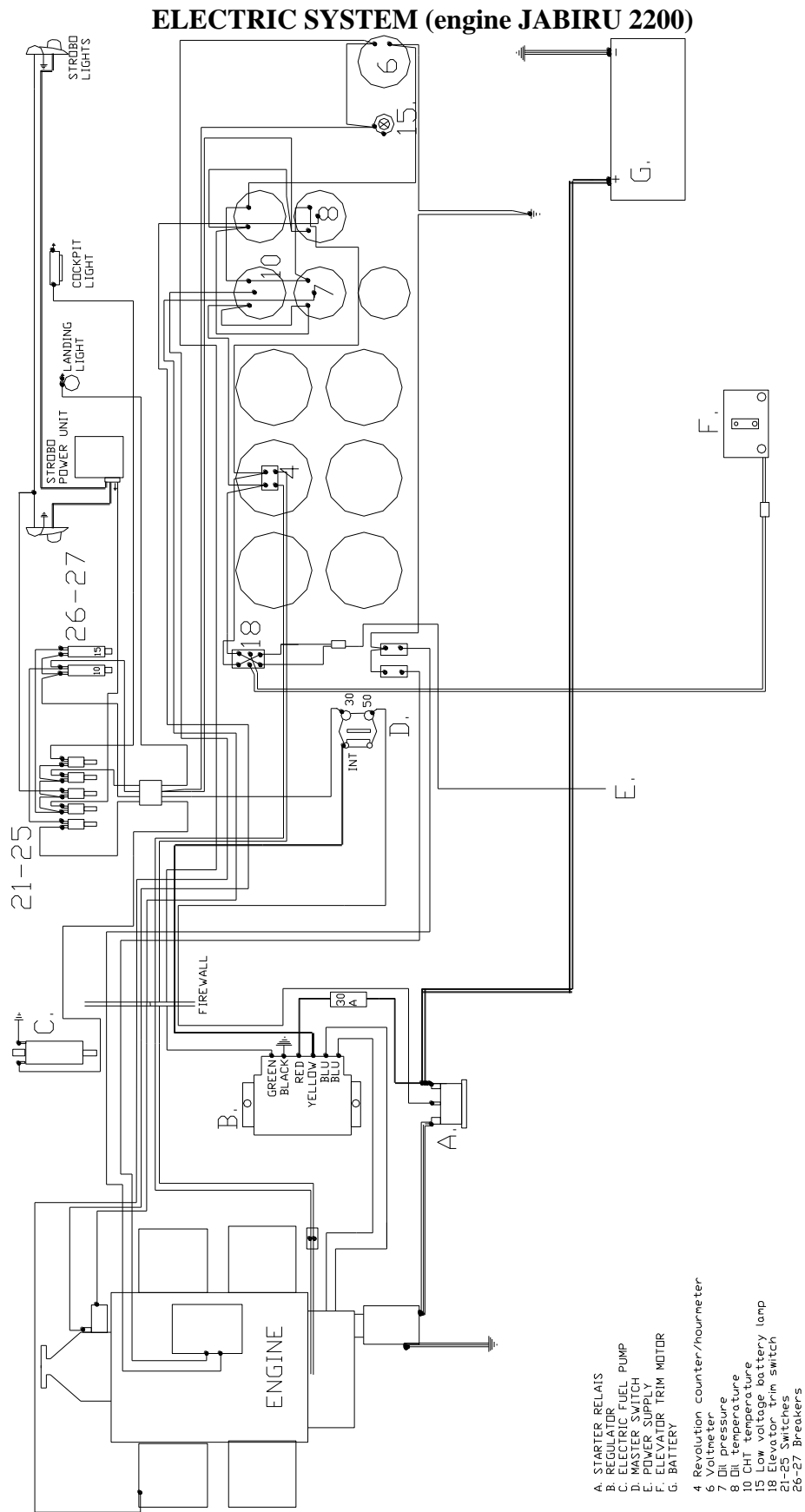

Figure nr.2



1.9 CABIN

Two large lateral doors allow an easy independent access to the cabin. They are hinged with two hinges on the upper edge of the doors. They may be locked by a key handle located in the lower edge and by a latch in the front edge. The doors may be removed unscrewing the hinges, if so desired (flying in hot regions or to take pictures). The doors **MUST NOT** be opened in flight.

WARNING: Is very important to verify that the latch in the front edge of the door is locked before taking off.

1.10 CABIN FEATURES AND UPHOLSTERY

The cabin arrangement features two canvas covered side-by-side seats.

1.11 VENTILATION

The cabin's ventilation is provided by an opening between the doors and the upper part of the cabin door frame. A dynamic air scoop intended to extract the cabin air is installed at the top of the baggage compartment. Cabin ventilation may be improved by using two rotating air scoops in the doors windows. It is important to achieve an efficient cabin ventilation to prevent windshield condensation in high humidity, low temperature weather conditions.

1.12 CABIN HEATING

On the upper right side of the instrument panel there is a push-pull control. Pull it for hot ventilation in the cockpit. The outlet may be opened by a rotating panel on the cockpit glare shield. The air is heated by a heat exchanger located around the muffler.

1.13 INSTRUMENT PANEL

ATTENTION:

The installed instruments are not certified according to any aeronautical regulations. Dangerous flight conditions should be avoided at all times. Do not consider the values given by the instruments as an absolute value.

As standard equipment the following instruments are fitted:

Each aircraft may have different instrument configuration according to customers request.

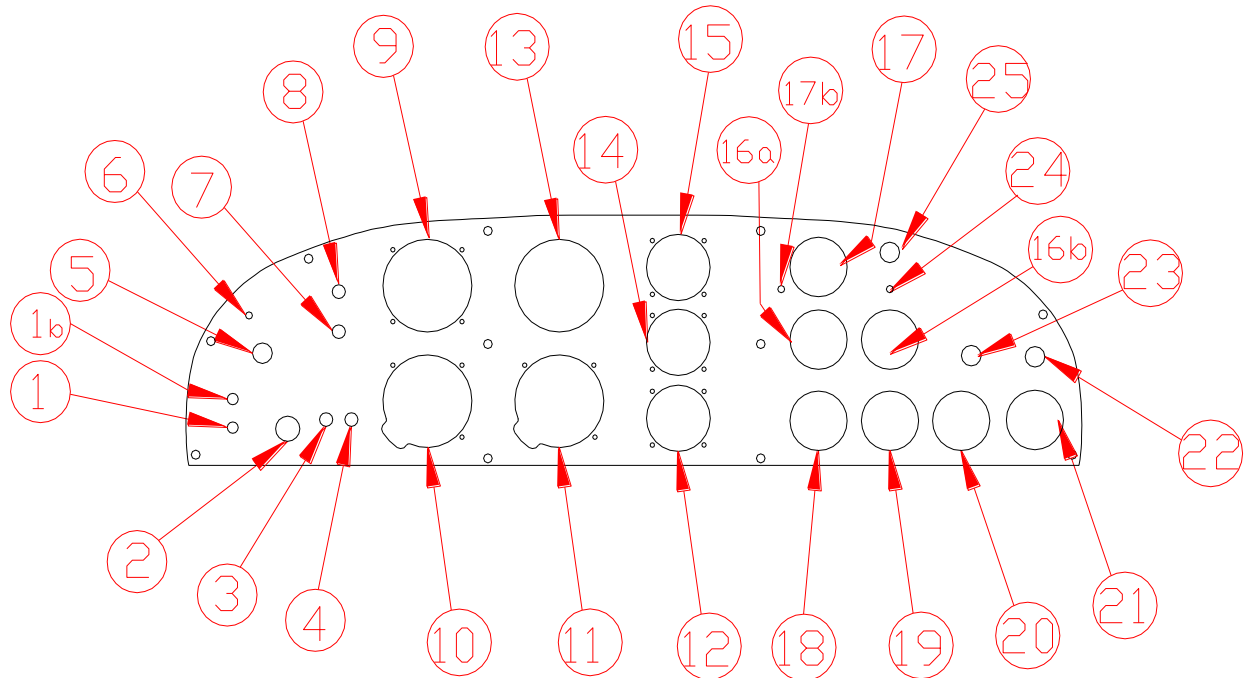

- 1 Choke actuator
- 1b Airbox control (Only Rotax 912 ULS)
- 2 Master switch
- 3,4 Magneto switches
- 5 Pilot side accelerator
- 6 PTT switch (optional)
- 7 Elevator trim switch
- 8 not used
- 9 Anemometer
- 10 Altimeter
- 11 Variometer
- 12 Radio-intercom (optional)
- 13 Revolution counter
- 14 Fuel pressure indicator
- 15 Slip indicator
- 16a Left cylinder head temperature
- 16b Right cylinder head temperature
- 17 External temperature (912 UL) + Airbox temperature (912 ULS)
- 17b Switch external temperature - airbox temperature (only 912 ULS)
- 18 Oil pressure indicator
- 19 Oil temperature indicator
- 20 Hourmeter
- 21 Voltmeter
- 22 Low battery voltage warning lamp
- 23 Passenger side accelerator
- 24 Reserve fuel tank (Nurise) test button
- 25 Fuel reserve warning lamp

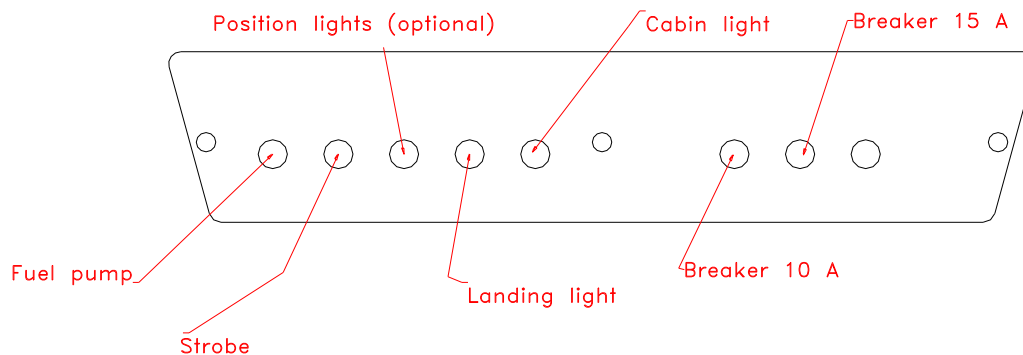

1.14 FLIGHT CONTROLS

The aircraft is controlled by a single “Y” shaped stick and dual conventional rudder pedals. Two operated brakes controls are installed on the pilot’s side only. The aircraft is equipped with one longitudinal electrical trim.

Flaperons range: $\pm 15^\circ (\pm 2^\circ)$
Elevator: UP $29^\circ \pm 3^\circ$, DOWN $25^\circ \pm 3^\circ$
Rudder range: $\pm 25^\circ (\pm 2^\circ)$

1.15 FLAPS CONTROL

In the Savannah, the system controlling the “flaperons” (a full-spaning trailing edge movable surfaces), is located on the cabin floor.

With the stick in the center and the flaps control lever full forward the flaps are fully retracted.

With the flaps control lever in the intermediate position the flaps are $20^\circ (\pm 3^\circ)$ down.

With the flaps control lever full back the flaps are fully extended $40^\circ (\pm 3^\circ)$ down.

In the Savannah VG is it possible to install an electric motor (installed under the pilot seat) to operate the “flaperons” with a switch on the instrument panel.

The maximum speed for flaps extension is 60mph (96Km/h).

1.16 PITOT-STATIC SYSTEM

The ram air to the pitot-static instruments is supplied by the Pitot tube located on the left hand forward wing strut.

No static pressure source is provided on the earlier model.

On later model the static pressure port is located on the left fuselage.

WARNING: blowing into the Pitot tube may damage the airspeed indicator.

1.17 BAGGAGE COMPARTMENT

An open space behind the seats is provided to carry some baggage up to 45 lbs.

The luggage **MUST** be evenly arranged on the baggage compartment floor and firmly fastened.

NOTE: the pilot **MUST** check, before every flight, that the weight and balance of the aircraft are within the allowed limits.

FLIGHT CONTROLS

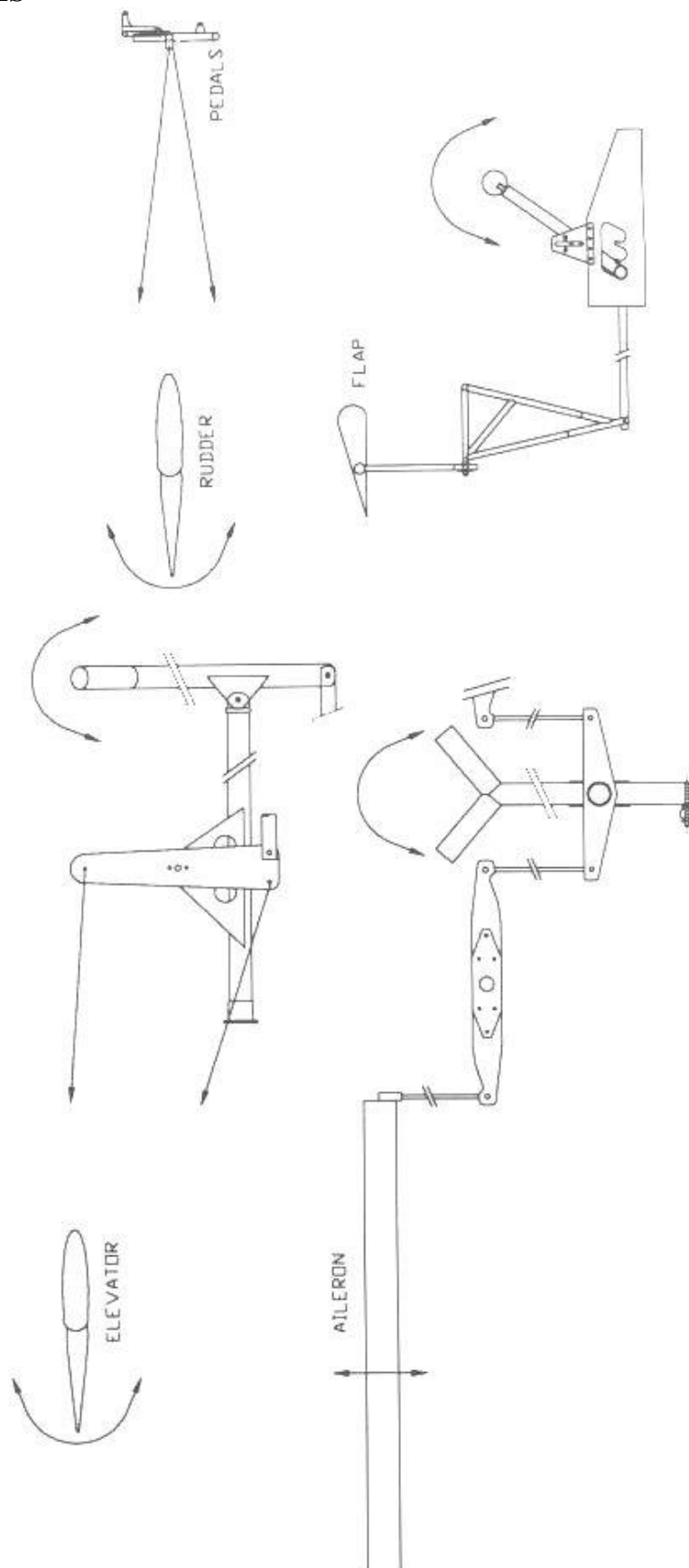

Figure nr.3

TABLE OF CONTENTS

SECTION 2

LIMITATIONS

Paragraph		Page
2.1	Speed limits	18
2.2	Load factors	18
2.3	Engine operations limits	18
2.4	Weight limitations	19
2.5	C of G limitations	19
2.6	Weather flying conditions	19
2.7	Type of maneuverings	19
2.8	Max demonstrated crosswind for T/O and landing	19

2.1 SPEED LIMITS

NOTE: the following speed limits (IAS) are set at a maximum take off weight of 1000 lbs/454 kg

Stall speed, full flaps, V _{so}	30 mph / 48 km/h
Flaps range (white arc)	30-60 mph / 48-96 km/h
Stall speed, no flaps, V _s	35 mph / 56 km/h
Normal operating range (green arc)	35- 93mph / 56-150 km/h
Max. maneuvering speed (1)	85 mph / 137 km/h
Caution zone (yellow arc) (2)	93-125 mph / 150-201 km/h
V _{mo}	100 mph / 160 km/h
Never exceeding speed, V _{ne} (red line)	125 mph / 201 km/h
Flaps speed limit	60 mph / 96 km/h

NOTES:

(1): the maximum maneuvering speed is the maximum speed at which the flight controls can be abruptly move to full deflection with out over stressing the airplane (maximum movable surfaces deflection angles);

(2): when flying in turbulence conditions this speed range has to be avoided.

2.2 LOAD FACTORS

Flaps retracted	+ 4 g	- 2 g
Flaps full extended	+ 2 g	----

NOTE: the maximum load factors (limit load factors) are obtained multiplying the above indicated values by the coefficient 1.5.

2.3 ENGINE OPERATIONS LIMITATIONS

- Maximum RPM for T/O and climb 5800 RPM (5 min.) (red line)
- Caution range 5500-5800 RPM (yellow arc)
- Normal range 1400-5500 RPM (green arc)
- Maximum continuous power 5500 RPM
- Idle speed around 1400 RPM
- Oil pressure normal range 2-5 bar (29-73 psi) (green arc)
caution range 5-7 bar (73-102 psi) (yellow arc)
min. 0.8 bar (12 psi) (red line), max 7 bar (102 psi) (red line)
- Oil temperature normal range 90-110 °C (green arc)
caution range 50-90 / 110-140 °C (yellow arc)
max 140 °C (red line)
- Fuel pressure **max 0.4 bar (5.8 PSI)**
Min 0.15 bar (2.2 PSI)
- Air-box temperatures (*Only 912 ULS*) Caution range 18 °C – 20 °C (yellow arc)
Caution range 24 °C – 35 °C (yellow arc)
Normal range 20 °C – 24 °C (green arc)
Minimum air box temp. 18 °C
Maximum air-box temp. 35 °C (red line)

ENGINE OPERATION LIMITATIONS (engine JABIRU 2200)

TABLE OF CONTENTS

SECTION 3

EMERGENCY PROCEDURES

Paragraph		Page
3.1	Emergency landing	21
3.2	Fire on the ground	21
3.3	Fire on the ground, engine operating	21
3.4	In flight fire	21
3.5	Cabin fire	21
3.6	Unintentional spins	21
3.7	Engine failure during T/O (on the ground) or immediately after T/O (low altitude)	22
3.8	Engine start during flight	22

3.1 EMERGENCY LANDING

Best glide speed	63 mph/100 km/h
Flaps	Retracted
Fuel valve	Shut-off
Engine	Shut-off
Seat belts	Fastened and tightened
Steep turns	Avoid
Flaps when landing is assured	Fully extended, 40°
Landing	Normal landing

3.2 FIRE ON THE GROUND

Starter	Keep cranking
Fuel valve	Shut-off
Throttle	Fully open, to burn the fuel and stop the fire

3.3 FIRE ON THE GROUND, ENGINE OPERATING

Fuel valve	Shut-off
Throttle	Fully open, to burn the fuel and stop the fire

3.4 IN FLIGHT FIRE

Fuel valve	Shut-off
Engine	Stop Don't try to restart the engine
Electrical system	All switches OFF
Landing	Go on to an emergency landing

3.5 CABIN FIRE

Electrical system	Master switch OFF
Fire extinguisher	Operate as necessary

3.6 UNINTENTIONAL SPINS

Rotation	To stop the rotation push the pedal opposite the rotation direction
Control stick	Center, slightly forward
Upon taking aircraft's control	Level flight attitude

3.7 ENGINE FAILURE DURING GROUND ROLL

Magneto switches	OFF
Master switch	OFF
Throttle	Idle
Fuel valve	Shut-off
Brake	Fully applied

Immediately after lift off

Airspeed	Keep 60 mph IAS and first notch of flap
Eventual landing	Check for adequate spaces within 30° left and 30° right
Throttle	50%, fuel pump ON and try to restart the engine
If previous point fails	Before touching the ground, magnetoes OFF, master switch OFF, throttle idle, fuel valve shut off
Flaps	Fully extended
On the ground	brake as necessary

3.8 ENGINE START DURING FLIGHT

Throttle	Idle
Magneto switches	ON
Master switch	ON
Fuel pump	ON
Restart the engine	-----
RPM	As needed

TABLE OF CONTENTS

SECTION 4

NORMAL PROCEDURES

Paragraph		Page
4.1	Before flight checks	24
4.2	Exterior checks	24
4.3	Engine start-up	24
4.4	Taxiing	26
4.5	Before take-off	26
4.6	Take-off and climb	27
4.7	Cruise	28
4.8	Descent	28
4.9	Approach and landing	28
4.10	Cross-wind landing	29
4.11	Sideslip	29
4.12	Aborted landing (Go-around)	29
4.13	Engine shut-down	29
4.14	Parking and tie-down	29

NOTE: The Savannah is an easy to handle airplane. No exceptional piloting skills are required to manouver the aircraft within its flight envelope.

4.1 BEFORE FLIGHT CHECKS

Master switch	OFF
Magnetos	OFF
Fuel selector	OPEN
Flight controls	UNLOCKED
Fuel gascolator	DRAIN
Powerplant fairings	FASTENED
Pre-flight/Daily inspection	PERFORMED

4.2 EXTERIOR CHECKS

Propeller and engine	Visual check the bolts and nuts, oil leaks
Forward landing gear	Visual check the connection points
Main landing gear and strut attachments	Visual check the bolts and nuts
Ailerons	Visual check the hinges, bolts and nuts
Horizontal and vertical tail	Visual check the attachment bolts and nuts
Coolant radiator	Visual check for absence of dirt, insects

4.3 ENGINE START-UP

COLD ENGINE	=====
Master switch	ON
Magnetos	ON
Brakes	APPLIED
Throttle	FULLY CLOSED (back)
Choke	ON (Rotax)
Starter	ENGAGE
NOTE	After engine start, let the engine run for few seconds then, gradually release the choke control while slightly pushing the throttle control forward

HOT ENGINE	=====
NOTE	Perform the same as for COLD ENGINE items except : Do not pull the choke control
NOTE	The engine starts easily with the throttle full closed. Only in case of fuel flooding it is useful to open the throttle to supply a large amount of air to recreate the normal carburation condition.
NOTE	It's strongly recommended that: The pilot, immediately before engaging the engine starter, shouts "CLEAR PROP". After visual verification that the propeller area is clear he can start the engine. If someone is standing close to the aircraft, it would be his responsibility to stay far enough away and answer to the pilot "PROPELLER CLEARED".
Engine warm-up	WAIT FOR PROPER CHT READING
Instruments operation	CHECK
Windshield cleanliness	CHECK
Brake effectiveness	CHECK
Safety belts and shoulder harnesses	FASTENED AND CHECKED
Fuel quantity	CHECK
Electrical devices operation	CHECK

4.4 TAXIING

POWER	Apply reduced engine power and use the brakes at the minimum
STEERING	Steer the airplane using the rudder pedals, not the brakes
CROSSWIND	In the event of a stronger than 19 mph/30 km/h crosswind, taxi at a very low speed and move the control stick laterally towards the up-wind wing; this will raise the up-wind wing flaperon reducing the possibility that the wing will accidental raise.
NOTE	Use rudder with the heels on the floor. That should prevent accidental brakes operation.

4.5 BEFORE TAKE-OFF

Altimeter	set
Trim	set to neutral position
Flaps retracted	CHECK
Flight controls freedom of movement and correct movement of surfaces	CHECK
Doors closed and locked	CHECK
Safety belts fastened	CHECK
Fuel level	CHECK
Engine instruments in correct working range	CHECK
NOTE	The engine has been running at 2500/3000 RPM while warming-up; the CHT reading has risen to 60 °C, oil 50 °C.
Magnetos; check the RPM drop: one magneto at a time at 3.000 RPM (the max. allowed drop is 300 RPM, the max difference between the two drops is 115 RPM)	CHECK
Magnetos	BOTH ON
Full power check	AS REQUIRED
Runway and circuit traffic	CLEARANCE CHECK
Runway threshold	LINE-UP

4.6 TAKE-OFF AND CLIMB

NORMAL TAKE-OFF	
Flaps, 20°	SET
Brakes	RELEASED
Air-box control	FULL FORWARD (COLD AIR)
Throttle (operate progressively)	FULLY OPENED
Engine RPM	CHECKED
Control stick	SLIGHTLY PULLED
NOTE	The aircraft will take-off at a 30-35 mph and will keep climbing at a 40-45 mph
NOTE	During take-off ground roll, be sure to put the heels on the cabin floor to avoid to inadvertently operate the brakes
Flaps, at a safe altitude	FULLY RETRACTED
Climb airspeed at 60-65 mph	SET
Upon reaching the required altitude	LEVEL
Cruise speed as required, RPM as required	SET
Trim (to relief pressure on the control stick)	SET
SHORT TAKE-OFF *	
Flaps, 40°	SET
Brakes	FULLY APPLIED
Throttle	FULLY OPENED
Air-box control	FULL FORWARD (COLD AIR)
Brakes	RELEASED
Pilot's heels	ON THE FLOOR
Nose-up attitude, control stick pulled-on until taking off	SET AND HOLD
Climb airspeed at 45 mph until the 50 ft obstacle clearing	SET
Flaps, upon reaching a safe altitude and airspeed	FULLY RETRACTED

NOTE *: The Short take off procedure is a very delicate maneuver. It is suggested to practice it with an instructor before attempting to perform it.

- the best rate of climb speed (V_y) will allow the aircraft to climb to the required altitude in the shortest flight time;
- the best angle of climb speed (V_x) will allow the aircraft to climb to the required altitude in the shortest distance;
- Using 20 flaps will increase the ground-roll distance (compared to 40 flaps) but will decrease the total take-off distance over 50ft obstacle. Using 40 flaps on take off will decrease the ground roll (compared to 20 flaps) but will increase the total take-off distance over 50ft obstacle.

In case of operation in Hi Density Altitude environment extending the flaps may not be beneficial. The increased induced drag generated in this condition, decreases the aircraft's performance. It is recommended to check the take-off performance chart to determine if the flaps extension is advantageous.

The above indicated data are based on an average aircraft. Actual values may vary base on the aircraft's weight and balance configuration.

4.7 CRUISE

The cruising speed is achieved at 75% engine power. Usually the propeller power (fixed pitch propeller only) will decrease by 50% with only a 20% RPM decrease. So, at a constant aircraft's configuration, the propeller will use the full engine power (full RPM) while, at 4.600 RPM, the propeller will be supplied with half the full engine power.

The cruise speed is 90 mph (5000rpm/27.2in.HG) with Rotax 912 UL and 95mph (5000rpm/26 in.HG) with Rotax 912 ULS and 85 mph with Jabiru 2200; remember that the faster the engine runs, the highest will be its fuel consumption and the lowest its operating life, while a slow running engine, for the same power output, will have its mechanical components loaded by greater forces and torques, thus increasing the risk to break rods, crankshaft and the other moving (rotating) parts. **Low RPM settings DON'T increase safety!**

Low RPM settings produce low power output thus a lower airspeed would be achieved.

Increasing the flight altitude will decrease the engine power output as well as the propeller's thrust: to compensate for the lost of power, it is required to increase the engine's RPM. The normal engine running speed is 4,000 to 5,400 RPM for Rotax 912 and 912S and 2500 RPM for Jabiru 2200.

The engine has been designed to be safely and continuously operated at the maximum RPM setting.

Air-box control: keep 20-24 °C of temperature. (Only Rotax 912 ULS)

4.8 DESCENT

To avoid shock cooling during the descent it is recommended not to operate the engine at idle. This should decrease the chances for cylinder heads cracks.

Keep air-box control pulled for hot air.

4.9 APPROACH AND LANDING

Throttle	IDLE
Airspeed	60 mph / 97 km/h (IAS)
Flaps	20 °
Airspeed	45 mph (IAS)
Flaps	40°
Airspeed	40 mph / 64 km/h (IAS)
Brakes, upon touching down	APPLY

If a higher rate of descent is required, fully extend the flaps. The angle of the descent path may be slightly varied by throttle operation as required to modify the gliding path. The flare will be flown in a nose-up attitude. Upon touching down, releasing the control stick will lower the nose.

If downwind attitude, keep air-box control pushed for cold air. (Only Rotax 912 ULS)

4.10 CROSS-WIND LANDING

In the event of a crosswind approach, either the sideslip technique (lowering the upwind wing and using cross rudder) or the crab technique (heading towards the wind) can be used.

Only the cross control technique can be used shortly before the ground contact. The maximum cross-wind component allowed during take-off and landing is 30/48 mph/km/h.

4.11 SIDESLIP

Sideslip is an approved operation during normal flight within green arc speed and within maneuvering speed if applied full flight controls excursion. Sideslip is approved also for approach maneuver, with the scope of increase the rate of descent with all flap configuration. To sidesliping, apply rudder and ailerons in opposite direction; control the direction with ailerons (more influent than rudder) and pitch with elevator. Airspeed indicator can be affected by an error for big sideslip angle; do not read in this case.

4.12 ABORTED LANDING (GO-AROUND)

Throttle, full power	SET
Flaps, when reaching a 54 mph (IAS) airspeed	RETRACT

The throttle control must be pushed smoothly and gradually to avoid an engine flooding or, worse, an engine stoppage.

4.13 ENGINE SHUT-DOWN

Engine operating, low RPM	2 MINUTES
Throttle	IDLE
Magnetos	OFF
Master switch	OFF

It's recommended to keep the engine running at low RPM for as long as two minutes in order to avoid a thermal shock and to achieve a thermal balance between the different engine's components. Moreover it will achieve a good pistons and piston rings lubrication so that the engine will be left in the best condition for the next start.

4.14 PARKING AND TIE DOWN

Tying the airplane down for a prolonged time in adverse meteorological conditions could cause damages at the attachment points.

An accurate inspection before flight is mandatory if such conditions exist.

To tie down the aircraft, tie two ropes to the rings installed under the wings near the strut attachments and a third one on the tail ring.

The tie down rings can be used when the the ground wind speed doesn't exceed 100km/h=62mph; when the wind speed exceed this value anchoring the nose wheel in coorespondence of the wheel pins is reccomanded

Tie the control stick together with the rudder pedals by using an elastic chord to lock all the movable surfaces.

Make sure the doors are closed and locked. Put in place the optional windshield and windows protection canvas to prevent dust accumulation and scratches.

TABLE OF CONTENTS

<i>Issue 1/Revision 04 Feb.2018</i>	ICP Srl – S.P.16 km 15,150 14022 Castelnuovo Don Bosco (AT) Tel. 011.9927503 Fax 011.9927266
---	---

SECTION 5
PERFORMANCE

Paragraph		Page
5.1	Stall speed	31
5.2	Take-off run	31
5.3	Landing distances	31
5.4	Rate of climb	32

5.1 STALL SPEED

NOTE: the speed values are expressed as anemometric (indicated) airspeed (IAS). It is assumed the aircraft and the powerplant are factory new and the airplane is flying in ISA conditions.

Stall speed	Maximum weight (1000/454 lbs/kg)
Flaps retracted	35 mph/56 km/h
Flaps extended (40°)	30 mph/48 km/h

The above indicated airspeeds are achieved with engine set to IDLE: in those situations the aircraft will simply sink with no change in the flight attitude when the control stick is pulled-up.

By applying power, the aircraft's nose will go up to a greater angle, the airspeed will decrease until the stall occurs, followed by a quick nose lowering.

NOTE: the maximum flaps extended airspeed is 60/96 mph/km/h (SavannahVG).

5.2 TAKE-OFF RUN

Take-off ground roll (hard surface, flaps 20°)	Maximum weight (1000/454 lbs/kg)
Sea level (MSL)	115 ft/35 m
3,000 ft/900 m pressure altitude	160 ft/50 m
6,000 ft/1,800 m press. altitude	210 ft/63 m

NOTE: if the airplane is operated from a grass runway the take-off ground roll will increase.

NOTE: The distance required to clear a 50ft (15m) high obstacle is the double of the take-off ground roll.

5.3 LANDING DISTANCES

The airplane needs 450ft (150m) for landing above 50ft (15m) obstacle, and a 150ft (50m) of landing run, in no wind condition at max gross weight, with an approach airspeed of 38-41mph (60-65km/h) IAS.

5.4 RATE OF CLIMB (Rotax 912 UL)

Rate of climb Full power setting	Maximum Gross weight (1000/454 lbs/kg)
Sea level (MSL)	1,200 fpm/5.5 m/s 48 mph/77 km/h
3,000 ft/900 m pressure altitude	790 fpm/4.0 m/s 45 mph/72 km/h
6,000 ft/1,800 m press. altitude	520 fpm/2.6 m/s 40 mph/64 km/h
9,000 ft/2,700 m press. altitude	300 fpm/1.5 m/s 37 mph/60 km/h

The maximum ceiling is 14000ft / 4200m pressure altitude at the maximum gross weight.

The best rate of climb speed is 56 mph (91km/h.)

The best gliding speed with flaps retracted is 63mph (100km/h). The gliding ratio is 1/11.

The fuel consumption at 75% power setting amounts to 4.9gph (18.5lt/h) for Rotax 912 ULS and 4.3gph (16.2lt/h) for Rotax 912 UL; 3.7gph (14 l/hr) for Jabiru 2200.

TABLE OF CONTENTS

SECTION 6

WEIGHT AND BALANCE

Paragraph		Page
6.1	General	34
6.2	Weight and balance sheet	35
6.3	Weight and balance drawings	36
6.4	Weight and balance pilot's computing table and graph	37

6.1 GENERAL

The aircraft CG (Center of Gravity) range is quite large. This makes the aircraft's loading and balancing easy to accomplish. By knowing the weights of the people, fuel and baggage to be carried on board and using the attached W&B sheet, the pilot would be able to check for the proper aircraft's weight and balance configuration. To find out the CG position, please refer to the attached table. Compute the total weight and the total moment by adding all the single weight and moments. An acceptable CG MUST be located into the area between the two limit lines.

WARNING: a CG beyond the most forward limit, as well as a CG beyond the most rearward limit may result in a VERY DANGEROUS flight condition.

NOTE: it is strictly forbidden to make any change or modification to the aircraft since those modifications may affect the balance limits set by the manufacturer.

6.2 WEIGHT AND BALANCE SHEET

Procedure to be used to determine the Center of Gravity position:

- The aircraft MUST be weighed with all equipments, accessories, engine oil, coolant and WITHOUT FUEL to determine the empty weight.

NOTE: all the fuel MUST be drained accurately.

- Place three weighting scales under the aircraft three wheels
- Make sure the aircraft is in the flight level position. To verify use a level positioned on the aircraft's upper skin of fuselage near cabin;
- Record the three weight measuring equipments readings: the nose wheel weight will be called P1, the left wheel weight P2, the right wheel weight P3;
- By using a plumbing wire attached to the leading edge, measure the distance D1 between the projection on the floor of the leading edge and the nose wheel axle, and the distance D2 between the same projected point and the main landing gear axle;
- By filling out the table below, make the calculations and find out the CG position. The airplane is in the correct balance if the line of the actual weight and the line of the actual total moment cross inside the white area.

TABLE TO DETERMINE THE AIRCRAFT'S BASIC EMPTY WEIGHT

Aircraft serial number	
Weight measuring equipment	
Location and date	
Certifying staff	

	<i>Weight (kg)</i>	<i>Arm (m)</i>	<i>Moment (kg x m)</i>
Nose landing gear	$P_1 =$	$D_1 =$	
LH main landing gear	$P_2 =$	$D_2 =$	
RH main landing gear	$P_3 =$	$D_2 =$	
TOTALS			

Signature	
-----------	--

6.3 WEIGHT AND BALANCE DRAWINGS

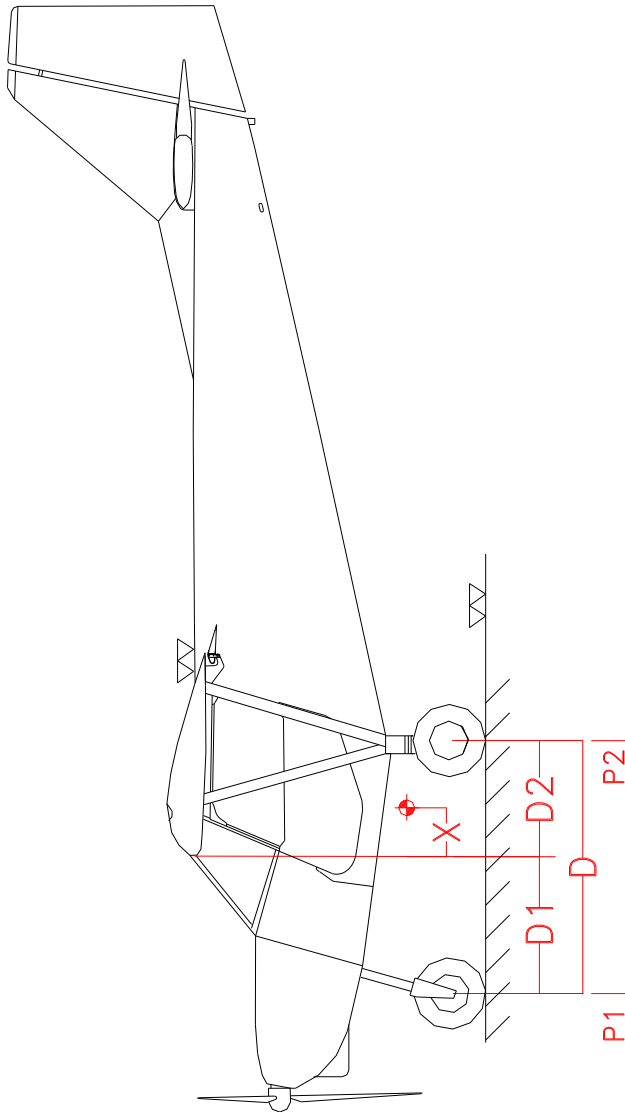

D1~750 mm

D2~690 mm

P1=weight on the nose landing gear

P2=total weight on the main gear

$x = (P2 * D) / (P1 + P2) - D1$

6.4 WEIGHT AND BALANCE PILOT'S COMPUTING TABLE AND GRAPH

COMPUTING TABLE

<i>Item</i>	<i>Weight W [lbs]</i>	<i>Arm X [m]</i>	<i>Moment [W x X]</i>
Basic empty weight			
Pilot		0.55	
Passenger		0.55	
Fuel (max 126 lb max)		0.495	
Baggage (45 lb max)		1.32	
TOTALS		=====	

GRAPH

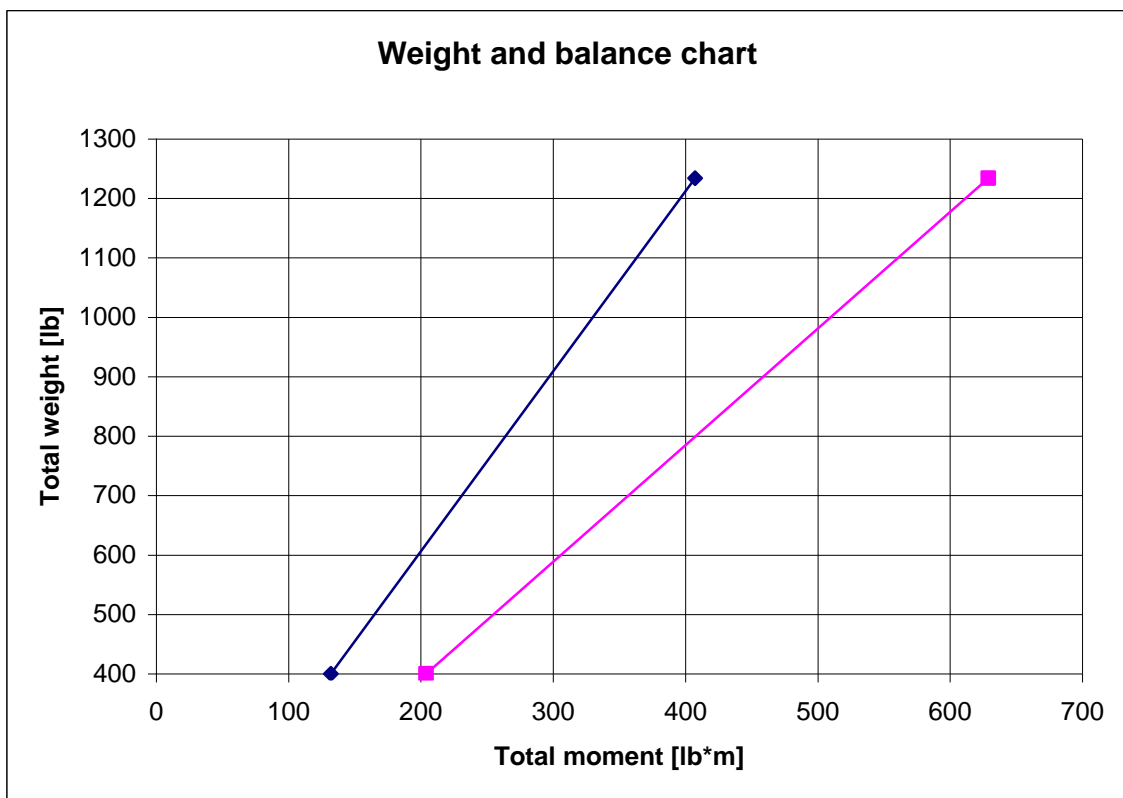

Forward C of G limit: 25% +/- 0.9 % MAC
 Rear C of G limit: 38.5% +/- 0.9 % MAC
 MAC: 1320mm

The content of the present manual is the sole property of I.C.P. srl and cannot be reproduced by third parties in any form whatsoever without ICP's previous written authorization.

Copyright I.C.P. 2002